

Amana[®]

Electric Cooktop Owner's Manual

AKR3001*

* Additional letters or numbers representing specific models or colors may follow each model number.

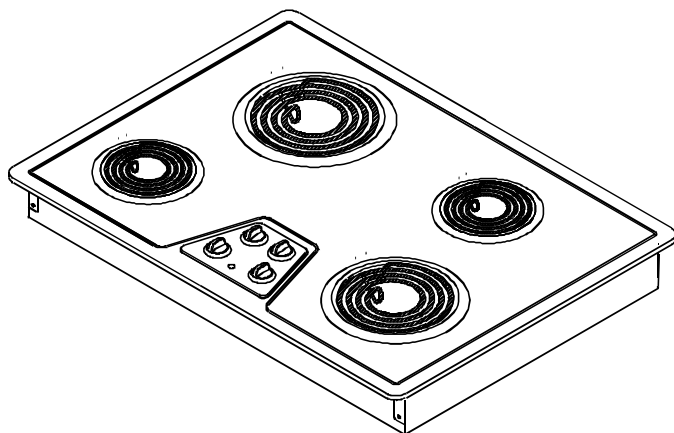

Para recibir un manual en español gratis, envíe por correo o por fax su nombre, dirección, y número de modelo a:

Amana Appliances
Consumer Communications/Spanish Manual
2800 220th Trail
Amana, Iowa 52204-0001
USA
Número de fax 1-319-522-8158

Please Read Manual Before Operating Cooktop

Important

Save for local electrical inspector's use.

Installer

Leave this manual and other literature with consumer for future use.

Customer

Keep these instructions for future reference. If appliance changes ownership, be sure this manual accompanies oven.

Contents

Model Identification	2
Parts and Accessories	2
Service	2
Asure™ Extended Service Plan	2
Important Safety Information	3
All Appliances	3
Surface Cooking Units	3
In Case of Fire	3
Precautions	3
Installation	4
Unpacking Cooktop	4
Counter Top Cutout and Clearances	4
Securing Cooktop to Countertop	5
Electrical Installation Requirements	5
Junction Box Location	5
Power Supply Connection	5
Removing and Reinstalling Cooktop	6
Operation	6
Operating Surface Elements	6
Cooking Utensils	6
Cleaning	7
Cleaning Cooktop	7
Cleaning Under Cooktop Surface	7
Warranty	8

Model Identification

Complete enclosed registration card and promptly return. If registration card is missing, call Consumer Affairs Department at 1-800-843-0304 inside U.S.A. 319-622-5511 outside U.S.A. When contacting Amana Appliances, provide product information located on rating plate. Rating plate is located on the oven frame. Record the following:

Model Number: _____
Manufacturing Number: _____
Serial or S/N Number: _____
Date of purchase: _____
Dealer's name and address: _____

Parts and Accessories

Purchase replacement parts and additional accessories (e.g., refrigerator shelves, dryer racks, or cooktop modules) over the phone. To order accessories for your product, call 1-800-843-0304 inside U.S.A. or 319-622-5511 outside U.S.A.

Service

Keep a copy of sales receipt for future reference or in case warranty service is required. Any questions or to locate an authorized servicer, call 1-800-NAT-LSVC (1-800-628-5782) inside U.S.A. 319-622-5511 outside U.S.A. Warranty service must be performed by an authorized servicer. Amana Appliances, also recommends contacting an authorized servicer if service is required after warranty expires.

Before You Call for Service

Review Owner's Manual before calling for service. If problems are not caused by defective workmanship or materials, or if part is consumer replaceable, you could be charged for a service call though product is under warranty.

- If control knob is on but element does not heat, check circuit breaker.

Asure™ Extended Service Plan

Amana Appliances offers long-term service protection for this new range. Asure™ Extended Service Plan is specially designed to supplement Amana Appliances's strong warranty. This plan covers parts, labor, and travel charges. Call 1-800-528-2682 for information.

Important Safety Information



WARNING

DO NOT TOUCH SURFACE UNITS OR AREAS NEAR UNITS—Surface units may be hot though they are dark in color. Areas near elements may be hot enough to burn. During and after use, do not touch or let clothing or other flammable material contact surface elements until they have had time to cool.



WARNING

To avoid risk of electrical shock, personal injury, or death, make sure your cooktop has been properly grounded and always disconnect it from main power supply before any servicing.



WARNING

Do not store gasoline or other combustible materials near cooktop.

All Appliances

1. Proper Installation—Be sure your appliance is properly installed and grounded by a qualified technician.
2. Never Use Your Appliance for Warming or Heating the Room.
3. Do Not Leave Children Alone—Children should not be alone or unattended in the area where the appliance is in use. They should never be allowed to sit or stand on any part of the appliance.
4. Wear Appropriate Apparel—Loose fitting or hanging garments should never be worn while using appliance.
5. User Servicing—Do not repair or replace any part of the appliance unless specifically recommended in the manual. All other servicing should be referred to a qualified technician.
6. Storage in or on Appliance—Flammable materials should not be stored on surface units.
7. Do Not Use Water on Grease Fires—Smother fire or flame, or use dry chemical or foam-type extinguisher.
8. Use Only Dry Potholders—Moist or damp potholders on hot surfaces may result in burns from steam. Do not let potholder touch elements. Do not use a towel or other bulky cloth.

Surface Cooking Units

1. Use Proper Pan Size—This appliance is equipped with one or more surface units of different size. Select utensils having flat bottoms large enough to cover the surface unit heating element. The use of undersized utensils will expose a portion of the heating element to direct contact and may result in ignition of clothing. Proper relationship of utensil to burner will also improve efficiency.
2. Never Leave Surface Units Unattended—Boilover causes smoking and greasy spillovers that may ignite.
3. Make Sure Reflector Pans or Drip Bowls Are in Place—Absence of these pans or bowls during cooking may subject wiring or components underneath to damage.
4. Protective Liners—Do not use aluminum foil to line drip bowls. Improper installation of these liners may result in a risk of electrical shock, or fire.
5. Glazed Cooking Utensils—Only certain types of glass, ceramic, earthenware, or other glazed utensils are suitable for range top service without breaking due to sudden change in temperature.
6. Utensil Handles Should be Turned Inward and Not Extend Over Adjacent Surface Units—To reduce the risk of burns, ignition of flammable materials, and spillage due to unintentional contact with the utensil, the handle of a utensil should be positioned so that it is turned inward, and does not extend over adjacent surface units.
7. Do Not Soak Removable Heating Elements—Heating elements should never be immersed in water.

IN CASE OF FIRE

Fires can occur as a result of over cooking or excessive grease. Though a fire is unlikely, if one occurs, proceed as follows:

Surface Element Fire

1. Smother the fire with a nonflammable lid or baking soda, or use a Class ABC or BC extinguisher. Not water. Not salt. Not flour.
2. As soon as it is safe to do so, turn the surface controls to “OFF”.

PRECAUTIONS

- Do not cook food directly on cooktop element, always use cookware.
- Do not mix household cleaning products. Chemical mixtures may interact with objectionable or even hazardous results.
- Do not put plastic items on warm cooking areas. They may stick and melt.
- Do not allow pots to boil dry as this can cause damage to cooking surface and pan.
- Do not use cooktop surface as a cutting board.

Installation

Unpacking Cooktop

- Remove all packing and printed material packed with cooktop.
- Slide cooktop out of box.
- To avoid damage, do not slide cooktop across counter top.

Counter Top Cutout and Clearances

Prepare counter top opening according to dimensions shown in diagrams.



WARNING

To avoid property damage or personal injury, observe the following specifications.



CAUTION

To avoid serious burns or other personal injury, do not store items of interest to children above or behind cooktop. Children climbing on cooktop to reach items could be seriously injured.

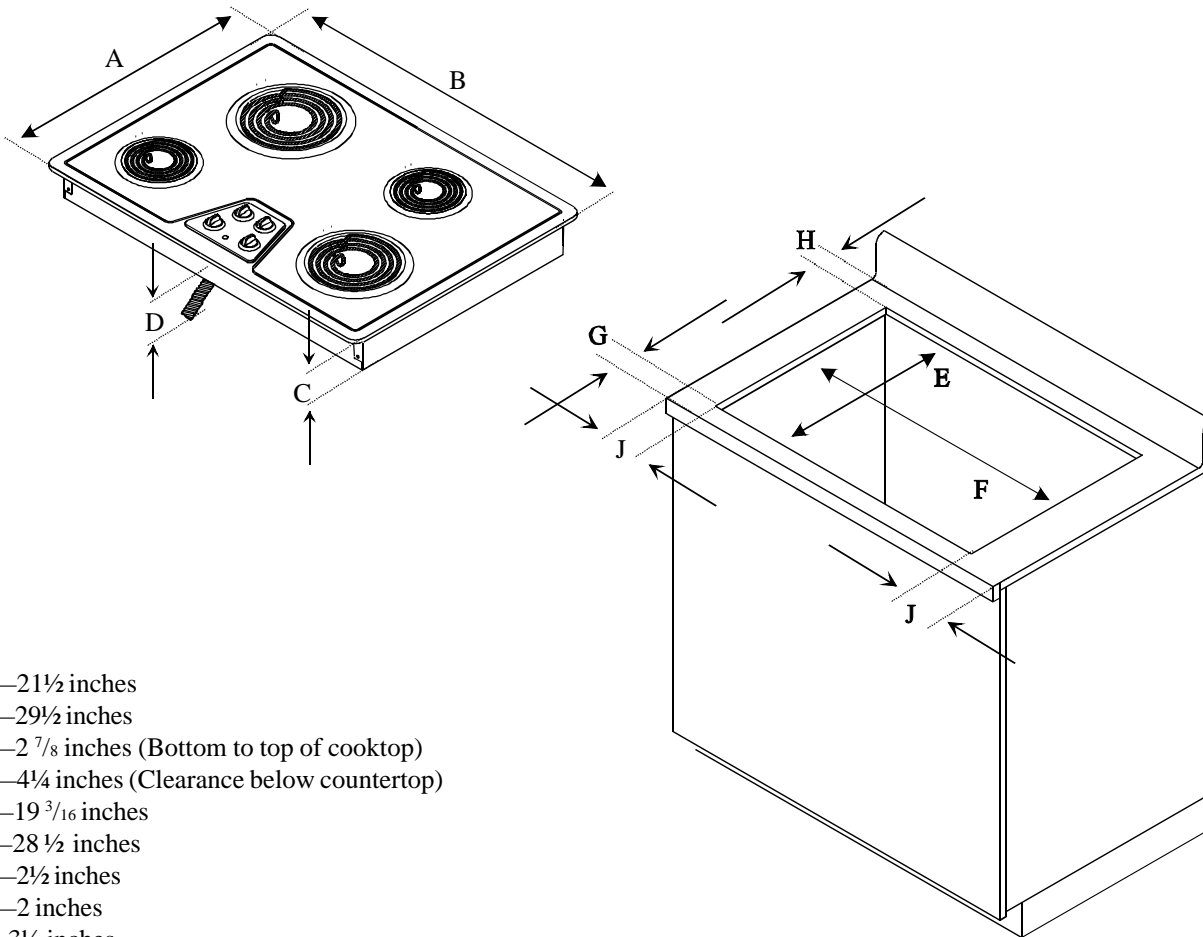

- A—21½ inches
- B—29½ inches
- C—2 ⁷/₈ inches (Bottom to top of cooktop)
- D—4¼ inches (Clearance below countertop)
- E—19 ³/₁₆ inches
- F—28 ½ inches
- G—2½ inches
- H—2 inches
- J—3½ inches

Cooktop and Cutout Dimensions

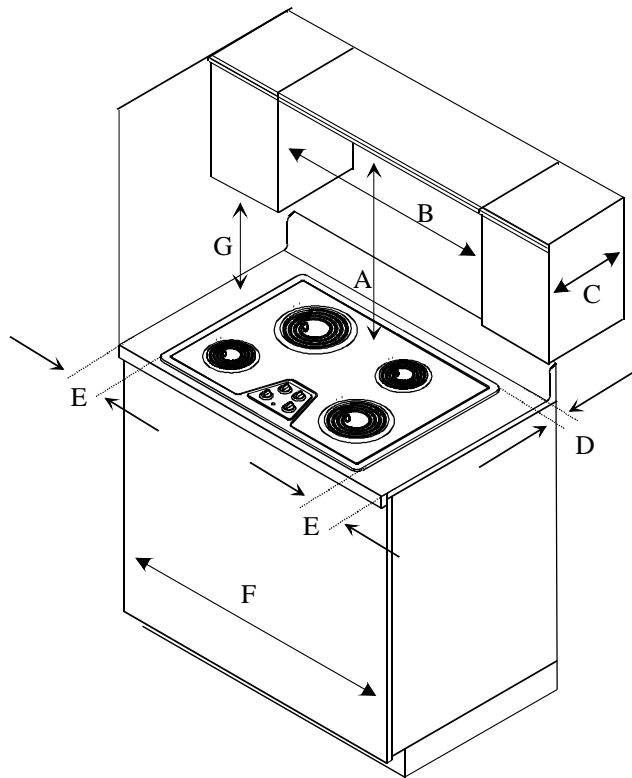

A —30 inches between cooking surface and un-protected wood or metal cabinet above cooktop. 24 inches between cooking surface and protected wood or metal cabinet above cooktop. Cabinet bottom must be protected by at least ¼ inch thick millboard with not less than No. 28 MSG sheet steel, .015 inch thick stainless steel, .024 inch thick aluminum, or .020 inch thick copper.

B —30 inches minimum

C—18 inches maximum

D—1½ inches minimum

E —3½ inches minimum

F—Single cabinet installation requires a 36 inch width base cabinet.

G—18 inches minimum

Minimum Clearances to Combustible Material

Securing Cooktop to Countertop

To stop cooktop from being lifted out or sliding in cutout, secure cooktop according to instructions.

1. Place cooktop in cutout.
2. Lift front of cooktop and prop open with rod hinged on bottom of cooktop.
 - Rear of cooktop is hinged.
3. Locate holes in each corner of burner box flange.
4. Drill hole through holes in flange into counter top.
 - Use size 5/64-inch drill bit.
 - Do not drill through counter top.
5. Insert screws provided into holes and tighten until cooktop is secure.

Electrical Installation Requirements

Installation of this product must conform with local codes or in the absence of local codes with the current National Electric Code ANSI NFPA 70.

Cooktop requires a 3-wire 240 volt, 60 hertz, AC circuit protected by a separate 30 amp circuit breaker or time delay fuse. Ground cooktop using #10 gauge ground wire attached to burner box.

Junction Box Location

Power supply enters cooktop under element control panel located in front center of cooktop. Junction box must be located within 30 inches of power supply entry point.

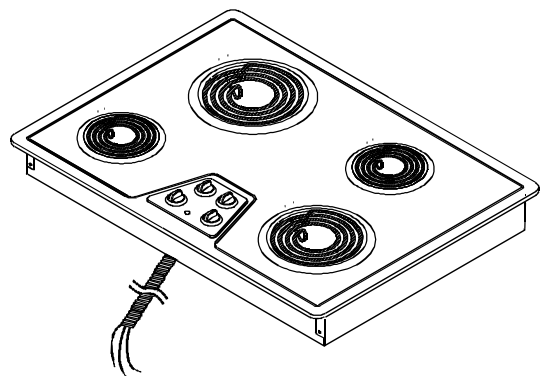

Power Supply Entry Point

Power Supply Connection



WARNING

To avoid risk of electrical shock, personal injury, or death, make sure your cooktop has been properly grounded and always disconnect it from main power supply before any servicing.



WARNING

To avoid risk of electrical shock or personal injury when connecting copper leads to aluminum house wiring, use only connectors designed for joining copper to aluminum. Follow connector manufacturer's recommendations closely .

To avoid risk of electrical shock or personal injury, do not ground through neutral wire if installed in mobile home or if local codes do not permit grounding through neutral wire.

Operation

Cooktop has approximately 36 inches of flexible wire conduit attached to rear of cooktop. Approximately 4 inches of green ground wire and 2 insulated wires, black and red, extend beyond end of conduit. Connect wire leads extending from conduit to house wires inside junction box (Junction box not included). Refer to local codes and attach according to examples below.

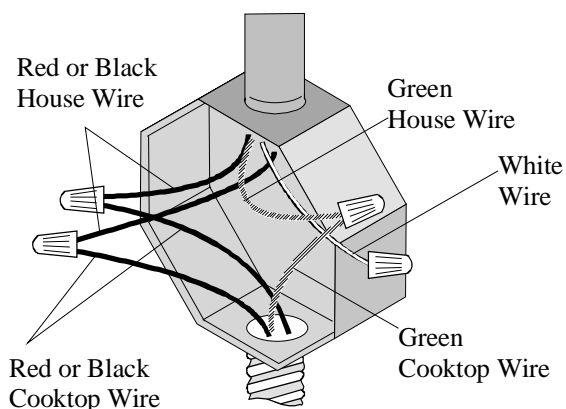

4-wire Connection

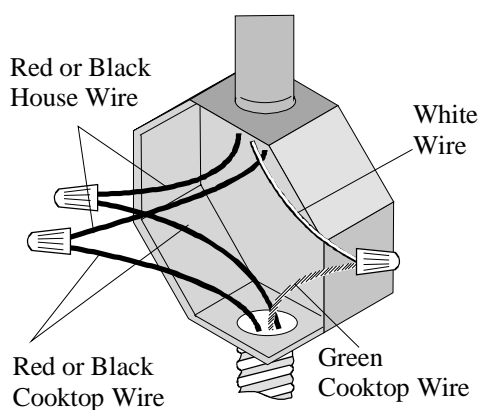

3-wire Connection

Removing and Reinstalling Cooktop

1. Turn off circuit breaker or electrical supply.
2. Disconnect cooktop wires from house wires.
 - See *Power Supply Connection* section.
3. Lift front of cooktop and prop open with rod hinged on bottom of cooktop.
 - Rear of cooktop is hinged.
4. Remove screws attaching burner box to counter top.
 - Screws located in each corner of burner box.
5. Lift cooktop out of cutout.
6. Reverse procedure to reinstall cooktop.

Operating Surface Elements

1. Push and turn control knob to desired setting.
 - Indicator light glows when one or more elements are heating.
2. Turn burner control knob to OFF position when finished.

LO—Use to prepare food at less than boiling temperatures or to simmer.

2 through 6—Use to maintain boiling of larger amounts of food, low temperature frying and to maintain correct pressure in a pressure cooker.

HI—Use to bring food to boiling temperatures. When food is boiling, temperature setting should be reduced.

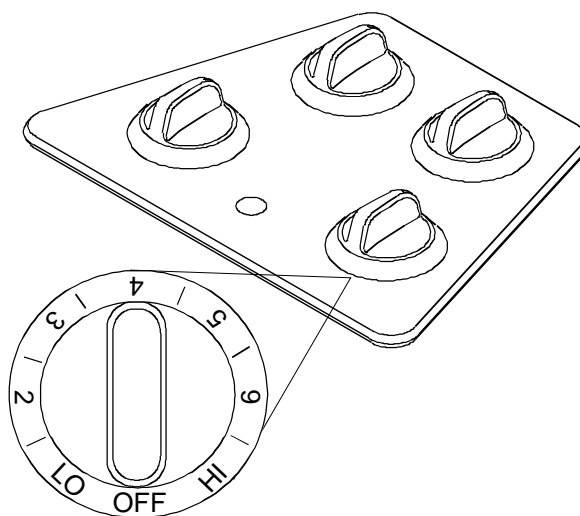

Surface Element Controls

Cooking Utensils

- Use proper pan size. Do not use utensils that overhang element by more than 1 inch.
- Use care when using glazed cooking utensils. Some glass, earthenware, or other glazed utensils break due to sudden temperature changes.
- Select utensils without broken or loose handles. Handles should not be heavy enough to tilt pan.
- Select utensils with flat bottoms.
- Do not use a wok with a ring stand.

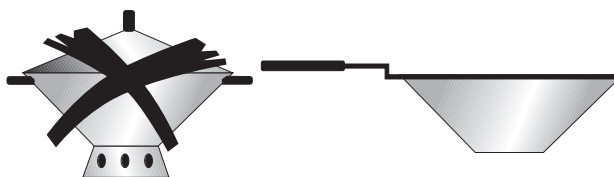

Use Flat Wok

Cleaning

For best cooking results, use a pan with a flat bottom. Determine if pan has a flat bottom.

1. Rotate a ruler along bottom of pan. If pan is not flat, gaps between bottom of pan and edge of ruler occur.
2. A small groove or mark on a pan does not affect cooking times. However, if a pan has a gap, formed rings, or an uneven bottom, it does not cook efficiently and in some cases may not boil liquid.

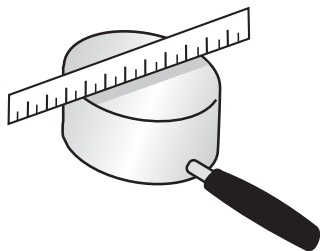

Use Flat Bottom Pans

Utensil Material Characteristic

Type	Temperature Response	Uses
Aluminum	Heats and cools quickly	Frying, braising, roasting
Cast Iron	Heats and cools slowly	Low heat cooking, frying
Copper Tin Lined	Heats and cools quickly	Gourmet cooking, wine sauces, egg dishes
Enamelware	Depends on base metal	Low heat cooking
Ceramic (Glass)	Heats and cools slowly	Low heat cooking
Stainless Steel	Heats and cools at moderate rate	Soups, sauces, vegetables, general cooking

WARNING

To avoid risk of electrical shock, personal injury, or death, make sure your cooktop has been properly grounded and always disconnect it from main power supply before cleaning.

Cleaning Cooktop

Clean cooktop, burner bowls, knobs, and gasket under control knobs with damp cloth and soapy water. If necessary, clean with nonabrasive cleaners or pads. Dry thoroughly when finished to avoid rusting.

- Do not use harsh powders, oven cleaners, scouring pads, or steel wool.
- Gasket under control knobs can be removed for cleaning.

Cleaning Under Cooktop Surface

1. Remove surface elements, burner bowls and control knobs.
2. Lift front of cooktop and prop open with rod hinged on bottom of cooktop.
 - Rear of cooktop is hinged.
3. Reverse procedure to reassemble.

Warranty

Amana[®] COOKING PRODUCTS (excluding wall ovens)

FULL ONE YEAR WARRANTY LIMITED SECOND YEAR WARRANTY ON ALL PARTS LIMITED THIRD THRU FIFTH YEAR WARRANTY ON GLASS/CERAMIC TOP, ELECTRIC SURFACE ELEMENTS, OR GAS SURFACE BURNERS

FIRST YEAR

Amana Appliances will repair or replace, including related labor and travel, any part (f.o.b. Amana, Iowa) which proves to be defective as to workmanship or materials.

SECOND YEAR

Amana Appliances will provide replacement part, part only (f.o.b. Amana, Iowa), which proves defective as to workmanship or materials.

THIRD THRU FIFTH YEAR

Amana Appliances will provide replacement glass/ceramic cooktop, part only (f.o.b. Amana, Iowa), which proves defective as to workmanship or materials.

THIRD THRU FIFTH YEAR

Amana Appliances will provide replacement electric surface elements or gas surface burners, part only (f.o.b. Amana, Iowa), which proves defective as to workmanship or materials.

OWNER'S RESPONSIBILITIES:

- Provide any defective part to an authorized Amana Appliances servicer.
- Provide proof of purchase.
- Provide normal care and maintenance, including cleaning as instructed in owner's manual.
- Replace owner replaceable items where directions appear in the owner's manual.
- Make product accessible for service.
- Pay for premium service costs for service outside servicer's normal business hours.
- Pay for service calls related to product installation and customer education.
- Pay for servicer's labor and travel expenses under limited warranty provisions.

ITEMS NOT COVERED:

- Normal product maintenance and cleaning.
- Light bulbs.
- Damages which occur in shipment and installation.
- General rebuilding or refurbishing that is not a legitimate warranty repair.
- Failures caused by:
 - Unauthorized service.
 - Grease or other material buildup due to improper cleaning or maintenance.
 - Accidental or intentional damage.
 - Connection to an improper gas or power supply.
 - Acts of God.
 - Use of improper pans, containers, or accessories that cause damage to the product.

WARRANTY LIMITATIONS:

- Begins at date of original purchase.
- Product used on a commercial, rental, or leased basis are not covered by this warranty.
- Applies to product used within the United States or in Canada if product has appropriate agency listing when shipped from the factory.
- Service must be performed by an authorized Amana Appliances servicer.
- Adjustments covered during first year only.

WARRANTY IS VOID IF:

- Serial plate is defaced.
- Product is altered by user.
- Product is not installed or used according to manufacturer's instructions.

IN NO EVENT SHALL AMANA APPLIANCES BE LIABLE FOR INCIDENTAL OR CONSEQUENTIAL DAMAGES*

*This warranty gives you specific legal rights and you may have others which vary from state to state. For example, some states do not allow the exclusion or limitation of incidental or consequential damages so this exclusion may not apply to you.

For answers to questions regarding the above or to locate an authorized Amana Appliances servicer, contact:

Amana Appliances
2800 220th Trail
Amana, Iowa 52204
USA
1-800-843-0304 inside U.S.A.
1-319-622-5511 outside U.S.A.